

Mycore Designers Catalogue

— Piero Lissoni

Mycore Designers Catalogue

– Piero Lissoni

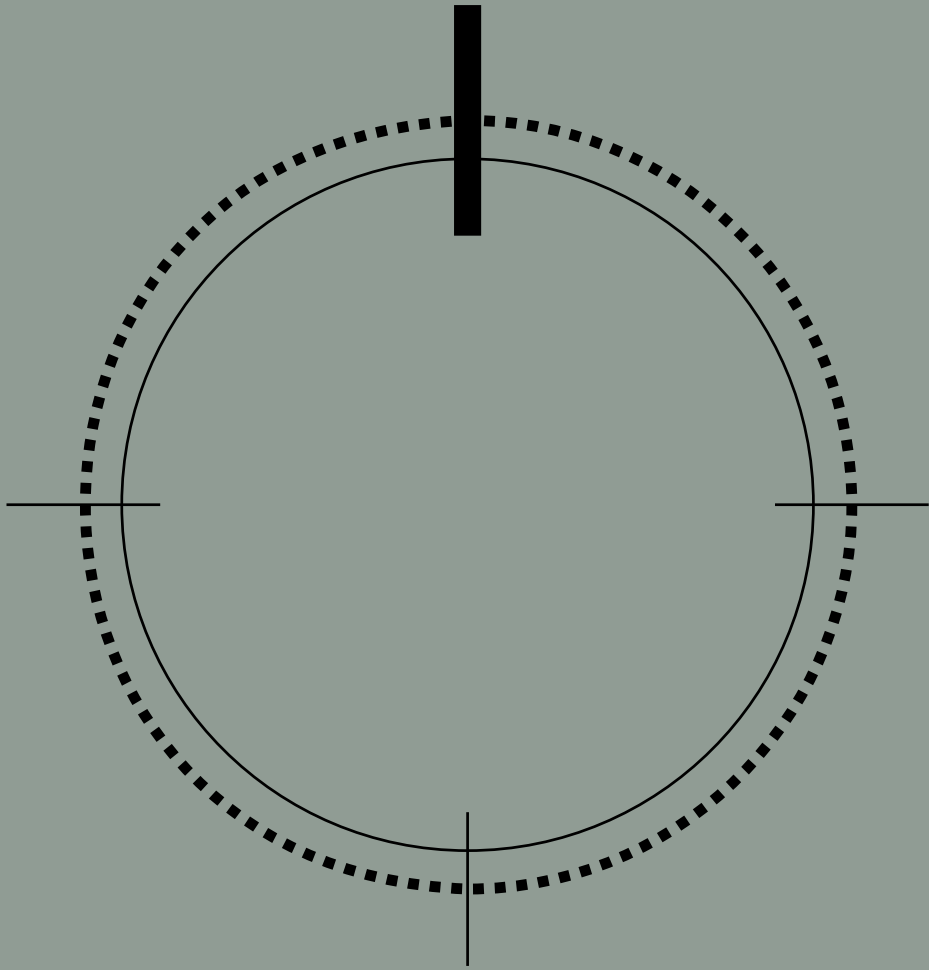

Contents

06 **New collection**

12 **Hyper**
Recessed
Incasso

22 **Leeway**
With track
Con binario

32 **Shard**
Without track
Senza binario

44 **Technical info**

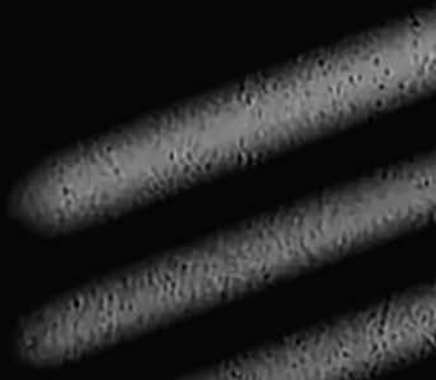



“

**To understand the light
I need the shadow.**

*Per poter capire la luce
ho bisogno dell'ombra.*

Piero Lissoni

New collection

**Aesthetic synthesis,
a harmonious fusion
of style and function,
and technical excellence:
an exclusive collection
of designer blinds
from the collaboration
of Mycore and Piero
Lissoni.**

*Sintesi estetica, fusione armonica tra stile
e funzione, eccellenza tecnica: dall'incontro
tra Mycore e Piero Lissoni, un'esclusiva
collezione di tende di design.*

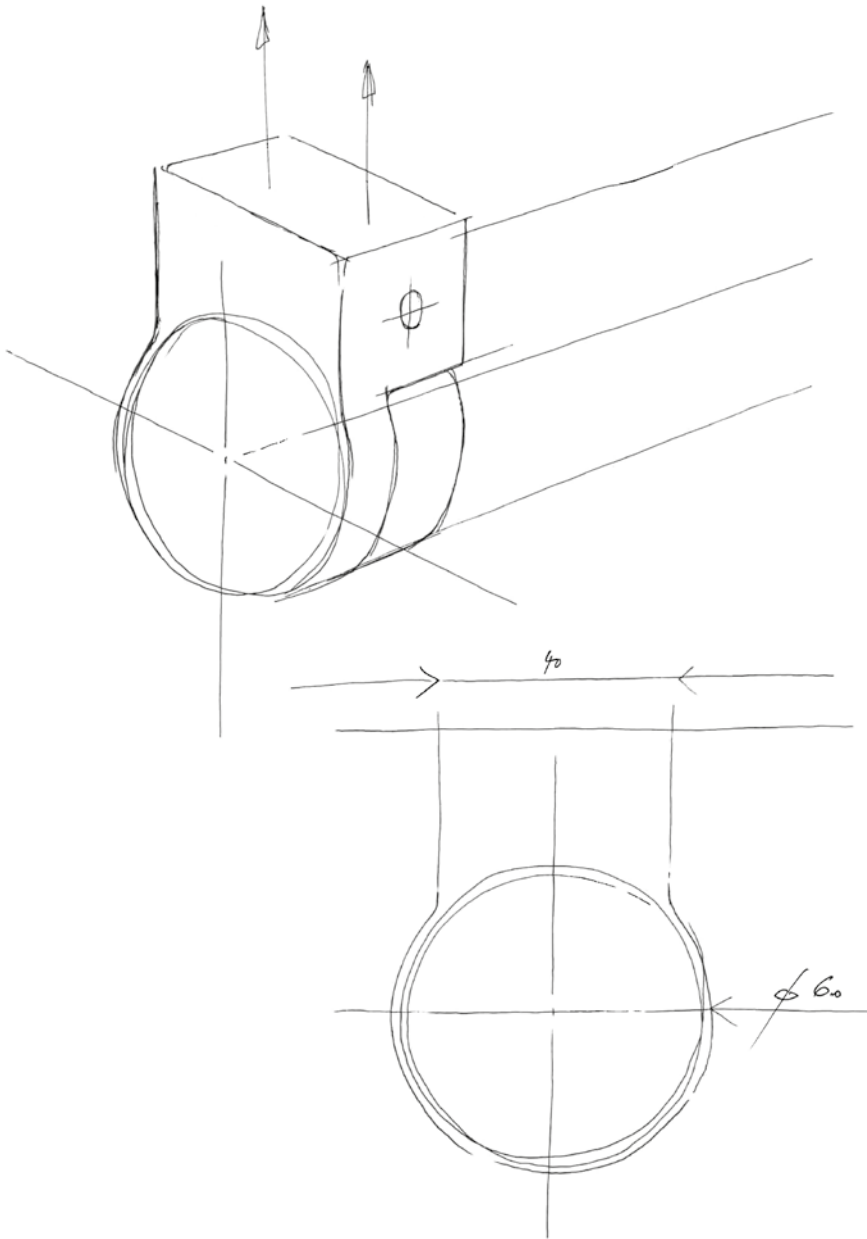

Relax. Immerse yourself in spaces flooded with a liquid light that softly filters in to illuminate the peace that you love so much. Your privacy is protected, your gaze relaxes. Interior and exterior meld together in a way never seen before, with daytime and nighttime light interacting in a continuous play of gentle scene changes.

Today, the essential aesthetics of Piero Lissoni are interwoven with Mycore's strong skills in the field of technical designer blinds to create an exclusive product that will light up your spaces to perfection every day.

This new line interprets contemporary tastes through products created with sartorial care over design and production: the most authentic expression of Made in Italy. A collection with timeless charm, skilfully designed to enhance residential and commercial spaces with light.

Rilassati. Lasciati avvolgere da ambienti inondati da una luce fluida che filtra soffusa ad illuminare la quiete che ami. La tua privacy è protetta, il tuo sguardo si distende. Interni ed esterni si fondono in modo inedito, luci diurne e notturne dialogano in un costante rimando fatto di morbidi cambi di scenario.

L'essenzialità estetica di Piero Lissoni oggi si intreccia con le solide competenze Mycore nell'ambito delle tende tecniche di design per dare vita ad un prodotto esclusivo, capace di illuminare ogni giorno la perfezione degli ambienti.

Questa nuova linea interpreta il gusto contemporaneo con prodotti frutto di una cura sartoriale sul fronte progettuale e produttivo, espressione del più autentico Made in Italy. Una collezione dal fascino senza tempo, sapientemente disegnata per valorizzare tramite la luce ambienti residenziali e spazi contract.

Piero Lissoni. Design takes shape.

Piero Lissoni. Il design prende forma.



An icon of Italian and international design and architecture, Piero Lissoni is the founder and driving force behind Studio Lissoni & Partners, which has been bringing together multiform skills and interests in projects with a highly recognisable visual identity for almost forty years.

Proportional harmony, the elegance of the overall effect and attention to detail are the principles guiding the development of designs that stand out for their precision and aesthetic synthesis. Studio Lissoni & Partners has brought together the development of brands with some of the best-known institutions using a holistic, sartorial approach that is able to encompass artistic direction and product design, interior architecture and graphics.

Now, Piero Lissoni has designed a new collection of Mycore products, created to embellish light with an original style.

Iconica firma del design e dell'architettura italiana e internazionale, Piero Lissoni è fondatore e anima dell'omonimo Studio Lissoni & Partners, che da quasi quarant'anni intreccia competenze e interessi multiformi in progetti con un'identità visiva di marcata riconoscibilità.

Armonia delle proporzioni, eleganza dell'insieme e cura dei dettagli sono le coordinate all'interno delle quali si sviluppano progetti che spiccano per rigore e sintesi estetica. Lo Studio Lissoni & Partners ha affiancato lo sviluppo di brand e istituzioni tra i più noti attraverso un approccio

olistico e sartoriale, capace di spaziare dalla direzione artistica al product design, dall'architettura agli interni, fino alla grafica.

Oggi Piero Lissoni firma una nuova collezione di prodotti Mycore, nati per vestire la luce tramite uno stile inedito.

“

It is an object you can hardly see, you have to make it work to filter the light. Like a lens that changes the relationship between inside and outside, and vice versa, but you can also make it invisible. An object designed almost inside out, like a lamp that does not give light, but instead creates shadows.

È un oggetto che quasi non si vede, bisogna farlo lavorare per filtrare la luce. È come una lente che cambia il rapporto tra dentro e fuori e viceversa, ma puoi anche azzerare la sua presenza. Un oggetto disegnato quasi al rovescio, come una lampada che però non serve a fare luce, ma a fare ombra.







“

**Light is
impressionism.**

*La luce è
impressionismo.*

Gae Aulenti



Hyper

Clean lines, in an authentically essential design. The support for the blind, concealed in a false ceiling, becomes invisible with Hyper. The narrow slot that allows the fabric to unroll is decorated with a minimalist frame: decor that perfectly fits with contemporary interiors and more classic rooms, for a timeless style.

Linee nette, in un design di autentica essenzialità. Il supporto della tenda, nascosto nel controsoffitto, con Hyper diventa invisibile. La sottile fessura che permette la discesa del telo è rifinita da una cornice minimale: un elemento d'arredo capace di interpretare interni contemporanei e spazi più classici, per uno stile senza tempo.

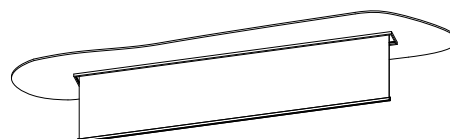

Installation

Hidden into plaster ceiling
A scomparsa nel controsoffitto

Type

Single or combined version
Singolo o abbinato

Product variants

Corner combination,
reduced false ceiling
*Combinazione ad angolo,
controsoffitti di piccole dimensioni*

Operation

Motorised system
A motore

Lowering of the fabric

In front or behind the roller
*Discesa del telo: davanti
o dietro all'avvolgibile*

Fabrics

Fabrics with different covering properties, sound-absorbing fabrics, printed fabrics and for video projection
Tessuti con diversi gradi di copertura, tessuti fonoassorbenti, tessuti stampati e per proiezioni video

Technical info

→ P. 46



Hyper

The blind allows you to adjust the light by superimposing filtering and darkening fabrics, and, once rolled up, restores the joy of large expanses of window.

La tenda permette di modulare la luce attraverso la sovrapposizione di teli filtranti e oscuranti, restituendo, una volta chiusa, l'emozione delle grandi aperture vetrate.

—
Picture
**Hyper / Double
Vertical**

—
Finishing
**Steel Grey
Brushed**

—
Fabrics
**5148/09
5101/10**









A fine frame in extruded aluminium or wood, with a minimalist design and made with 45° precision cutting, guaranteeing the best possible construction quality and aesthetic results.

Una sottile cornice in alluminio estruso o legno, caratterizzata dal design minimale e realizzata con tagli di precisione a 45°, che garantiscono la massima qualità costruttiva e resa estetica.

Finishes

Finiture

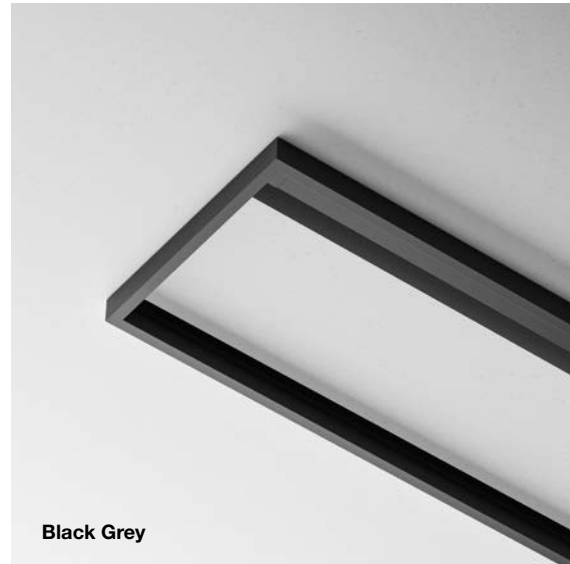

Available in four different finishes, Hyper can express different moods and styles, ranging from the simplicity of white to the textured intensity of wood.

Disponibile in quattro diverse finiture, Hyper permette di interpretare stili e mood differenti, spaziando dall'essenzialità del bianco al sapore materico del legno.









Leeway

A union of showmanship and minimalism: Leeway includes an attachment for the roller blind using an elegant aluminium bar, which provides flexibility in terms of installation and enhances the space with the beauty of the materials and its clean design.

L'unione tra presenza scenica e minimalismo: Leeway prevede l'aggancio della tenda a rullo tramite un'elegante barra di alluminio, che regala flessibilità installativa e impreziosisce l'ambiente con la bellezza dei materiali e la pulizia del design.

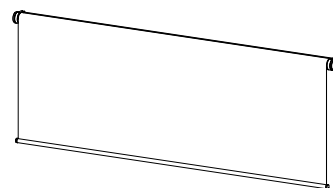

Installation

Ceiling or wall mounted
A soffitto o a parete

Type

Single or combined version
Singolo o abbinato

Products variants

Fixed support or movable along the track (requires the intervention of an installer)
Supporto fisso o spostabile lungo il binario (richiede l'intervento di un installatore)

Operation

Moved by chain or motorised system
A catena, a motore

Lowering of the fabric

Standard in front of the roller
Discesa del telo: standard davanti all'avvolgibile

Fabrics

Fabrics with different covering properties, sound-absorbing fabrics, printed fabrics and for video projection
Tessuti con diversi gradi di copertura, tessuti fonoassorbenti, tessuti stampati e per proiezioni video

Technical info

→ P. 52



Mycore

24

Leeway

Synergy with the architectural space and increased functionality: Mycore fabrics allow you to screen the light and improve the insulation of the building.

Sinergia con lo spazio architettonico ed elevata funzionalità: i teli tecnici Mycore consentono di schermare la luce e migliorare l'isolamento energetico dell'edificio.

—
Picture
Leeway / Wall

—
Finishing
Black Grey

—
Fabric
5187/07









Leeway

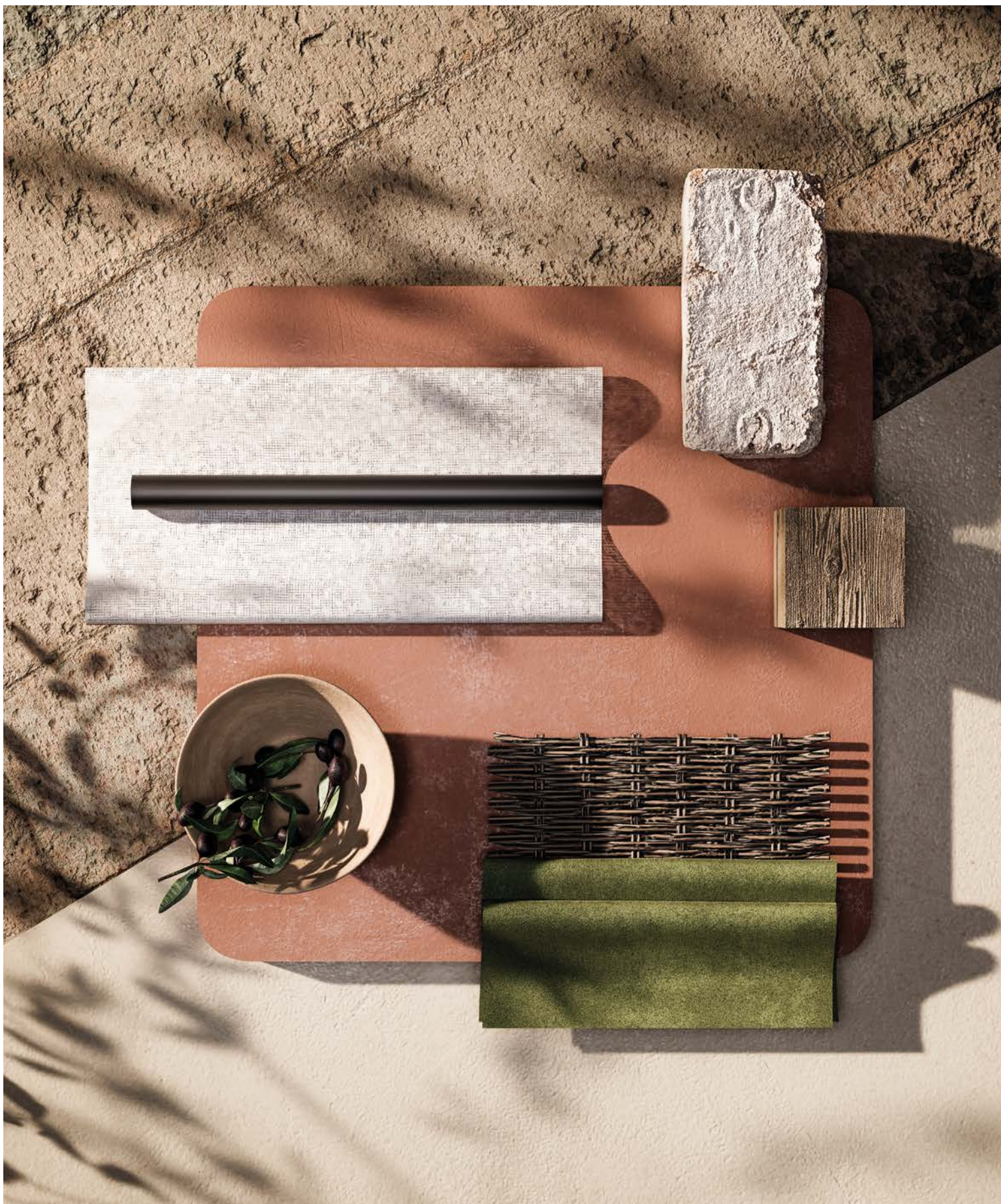

Finishes *Finiture*



Pure White 9010



Black Grey



Steel Grey

Aluminium machined from solid available in three finishes, for a technical and functional element that also becomes an elegant piece of furniture.

Alluminio scavato dal pieno disponibile in tre finiture, per una componente tecnica e funzionale che diventa prestigioso elemento d'arredo.







Shard

With an extremely compact appearance, Shard juxtaposes soft, beguiling lines with decisive, clean-cut edges, creating a harmonious overall effect that is dynamic, energetic and light.

Attraverso una veste visiva di estrema compattezza, Shard accosta linee progettuali morbide e avvolgenti, con profili netti e decisi, definendo un insieme armonico di forte dinamismo, energia e leggerezza.

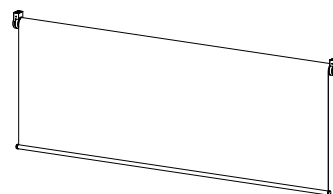

Installation

Ceiling or wall mounted
A soffitto o a parete

Type

Single or combined version
Singolo o abbinato

Operation

Moved by chain
or motorised system
A catena, a motore

Lowering of the fabric

Standard in front of the roller
Discesa del telo: standard davanti all'avvolgibile

Fabrics

Fabrics with different covering properties, sound-absorbing fabrics, printed fabrics and for video projection
Tessuti con diversi gradi di copertura, tessuti fonoassorbenti, tessuti stampati e per proiezioni video

Technical info

→ P. 54



Shard

The supports and fabrics are designed and fine-tuned to create an aesthetically perfect result, seen from both indoors and outdoors.

Supporti e teli sono progettati e rifiniti con cura per risultare perfetti nell'estetica sia dagli interni, sia dagli esterni.

—
Picture
Shard / Top

—
Finishing
Pure White 9010

—
Fabrics
5081/10









Highly refined weaves combined with innovative technical functions, all available in Mycore's extensive catalogue.

Trame ricercate, unite a funzionalità tecniche innovative, da scegliere nell'ampio catalogo tessile Mycore.

Finishes

Finiture



Matt coatings, made in Italy, guarantee sophisticated design that keeps its charm over time.

Verniciature opache, realizzate in Italia, assicurano un design pregiato che mantiene il suo fascino nel tempo.

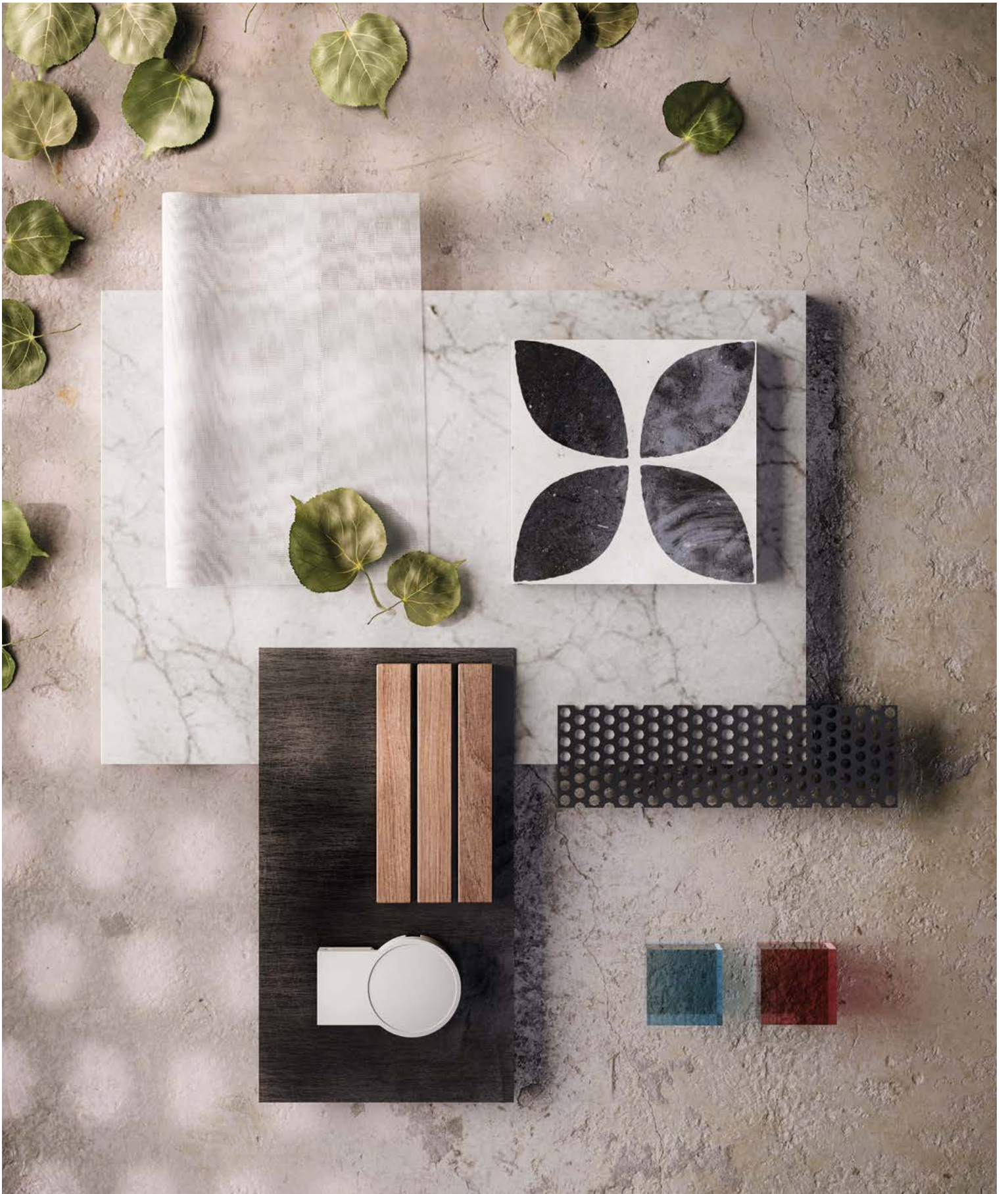



Refined weaves *Trame preziose*

Visual continuity between outdoor and indoor spaces, or diffused light and privacy: for every occasion, our blinds bring the perfect setting to life.

Continuità visiva tra spazi esterni e interni, oppure luce diffusa e privacy: di volta in volta la tenda dà forma allo scenario perfetto.

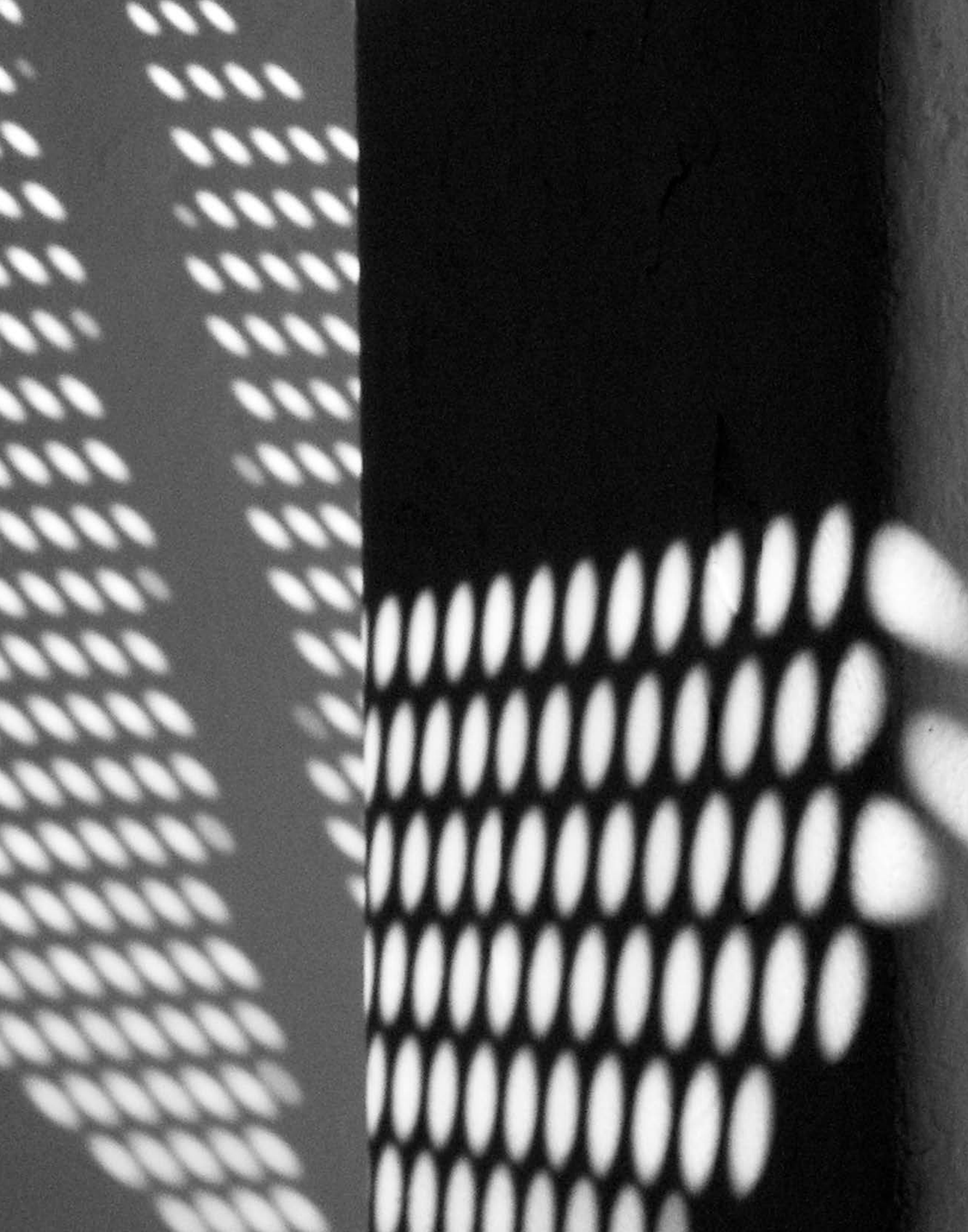



“

**Every moment of light
and dark is a miracle.**

*Ogni momento di luce
e oscurità è un miracolo.*

Walt Whitman

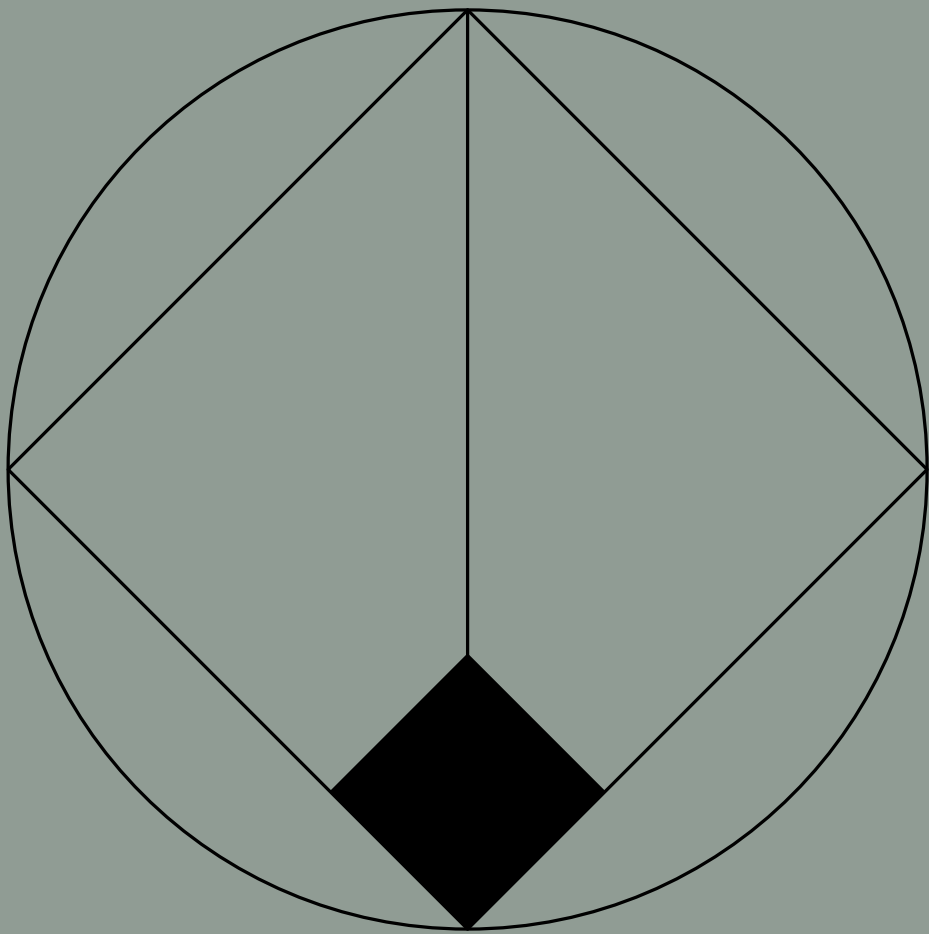

Solutions for enhancing the light in every space.

Soluzioni per vestire la luce, in ogni ambiente.

Perfectly calibrated mechanisms, carefully selected materials, processes designed to guarantee excellent functioning, minimal maintenance of supports and fabrics, and long life: the collection signed by Mycore and Piero Lissoni interprets the essence of authentic Made in Italy.

From this collaboration comes a line skilfully designed to furnish private homes and commercial spaces with a wide range of possible technical solutions, dimensions and configurations.

Meccanismi perfettamente calibrati, materiali selezionati con cura artigianale, lavorazioni studiate per garantire l'eccellenza del funzionamento, minima manutenzione dei supporti e dei teli e durata senza limiti: la collezione firmata da Mycore e Piero Lissoni interpreta l'essenza dell'autentico Made in Italy.

Da questa collaborazione nasce una linea sapientemente disegnata per vestire abitazioni private e spazi contract con un ampio ventaglio di soluzioni tecniche, dimensioni e configurazioni possibili.

Hyper — 1

Standard

Front view
Vista frontale

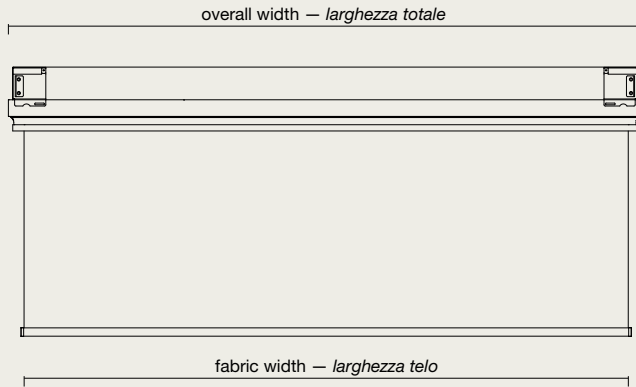

Version: SF
Variante: SF

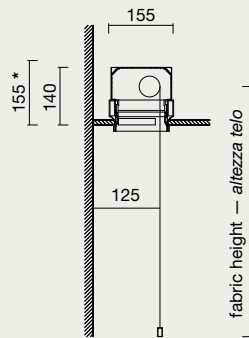

Fabric lowering: front (standard)
Discesa telo: avanti (standard)

Version: SB
Variante: SB

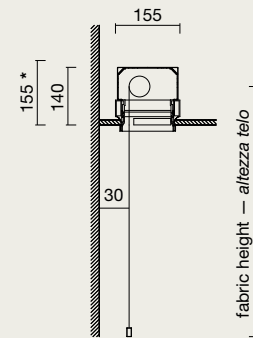

Fabric lowering: behind
Discesa telo: dietro

Multiple combination

Combinazione multipla

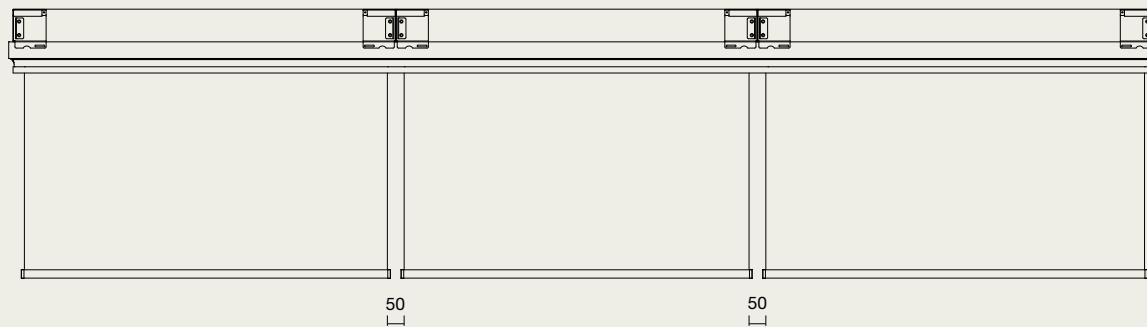

Front view
Vista frontale

Corner combination

Combinazione ad angolo

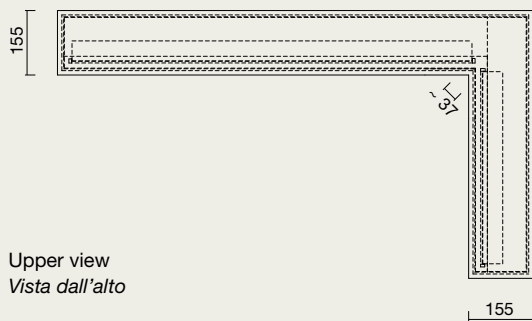

Upper view
Vista dall'alto

Version: reduced false ceiling
Variante: controsoffitti di piccole dimensioni

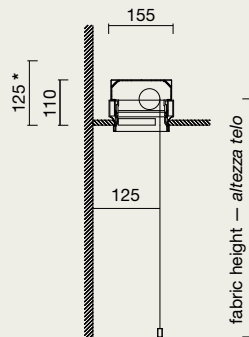

Fabric lowering: front (standard)
Discesa telo: avanti (standard)

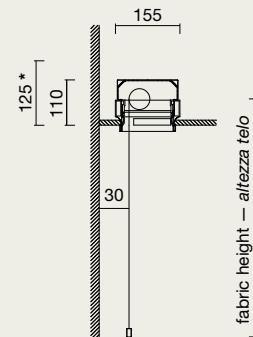

Fabric lowering: behind
Discesa telo: dietro

* Necessary space to install the system on wall (using wall cupboard fixing bar)
Spazio necessario per l'installazione a parete (con barra portapensile)

Maxi

Front view
Vista frontale

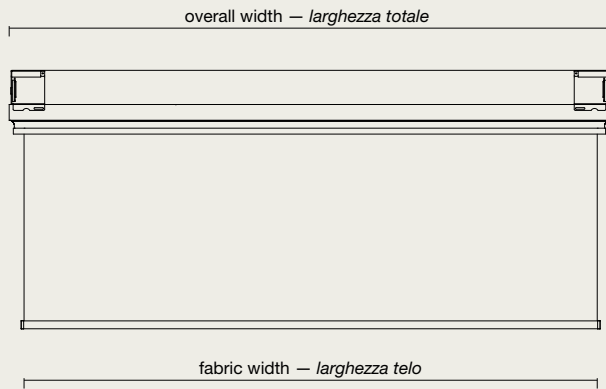

Version: SF
Variante: SF

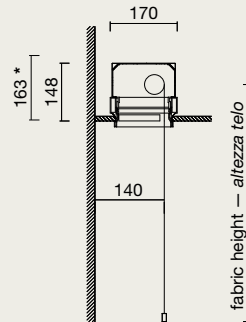

Fabric lowering: front (standard)
Discesa telo: avanti (standard)

Version: SB
Variante: SB

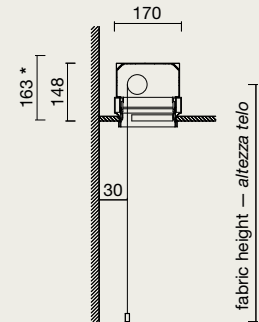

Fabric lowering: behind
Discesa telo: dietro

Multiple combination

Combinazione multipla

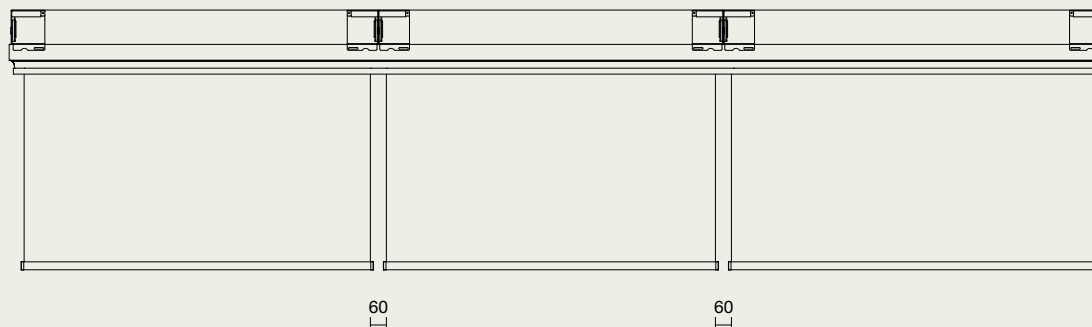

Front view
Vista frontale

Corner combination

Combinazione ad angolo



Upper view
Vista dall'alto

* Necessary space to install the system on wall (using wall cupboard fixing bar)
Spazio necessario per l'installazione a parete (con barra portapensile)

Hyper — 2

Double / Vertical

Front view
Vista frontale



Version: DVB
Variante: DVB

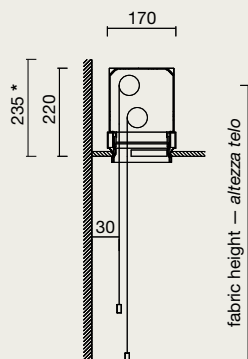

Fabric lowering: behind (standard)
Discesa telo: dietro (standard)

Version: DVF
Variante: DVF

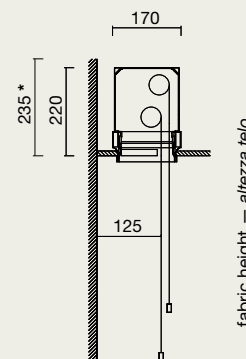

Fabric lowering: front
Discesa telo: avanti

Multiple combination
Combinazione multipla

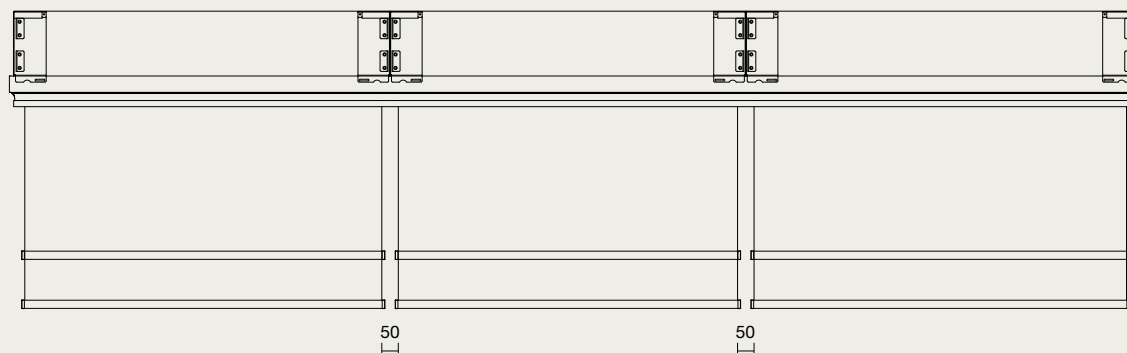

Front view
Vista frontale

Corner combination
Combinazione ad angolo



Upper view
Vista dall'alto

* Necessary space to install the system on wall (using wall cupboard fixing bar)
Spazio necessario per l'installazione a parete (con barra portapensile)

Double / Horizontal

Front view
Vista frontale

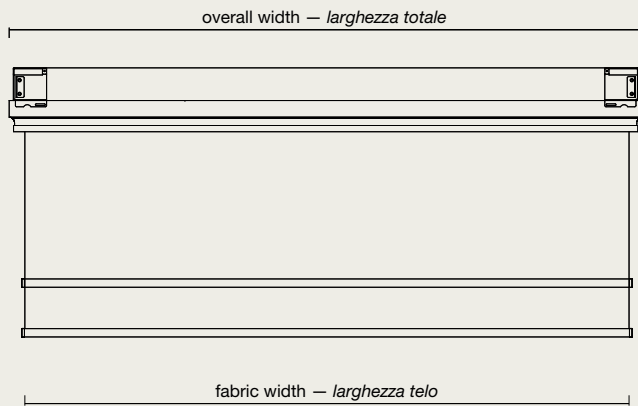

Version: DOB
Variante: DOB

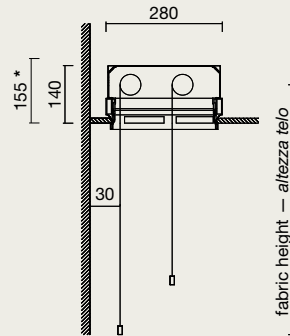

Fabric lowering: behind (standard)
Discesa telo: dietro (standard)

Version: DOM
Variante: DOM

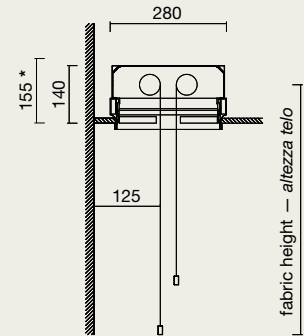

Fabric lowering: middle
Discesa telo: centrale

Multiple combination

Combinazione multipla

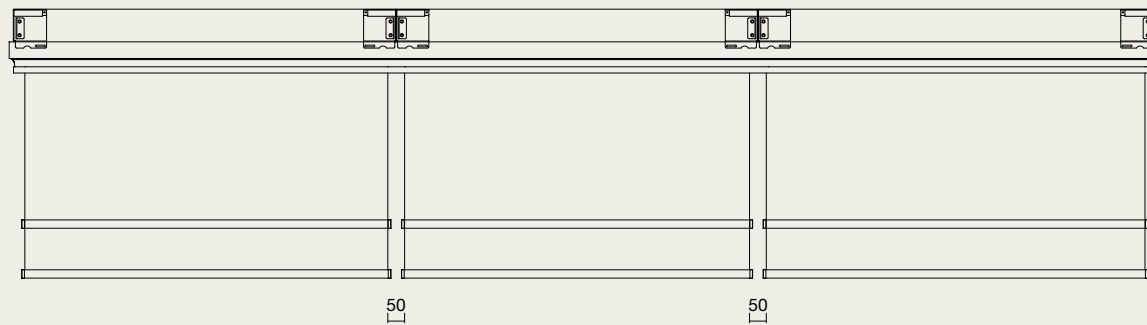

Front view
Vista frontale

* Necessary space to install the system on wall (using wall cupboard fixing bar)
Spazio necessario per l'installazione a parete (con barra portapensile)

Hyper — 3

One on One / Vertical

Front view
Vista frontale

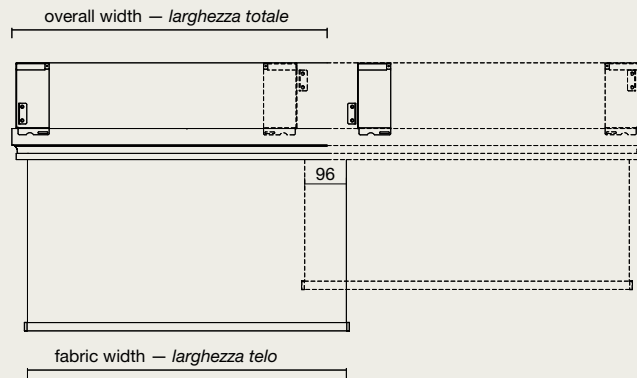

Version: NVF
Variante: NVF

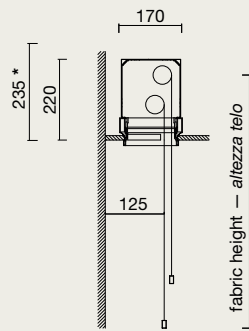

Fabric lowering: front (standard)
Discesa telo: avanti (standard)

Version: NVB
Variante: NVB

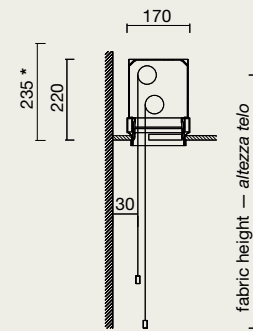

Fabric lowering: behind
Discesa telo: dietro

Multiple combination
Combinazione multipla

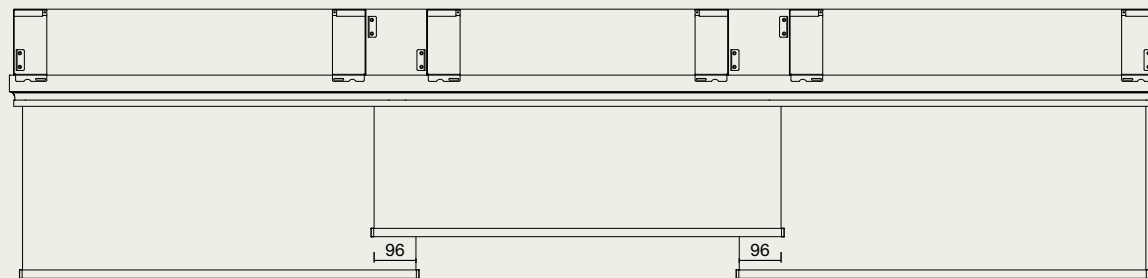

Front view
Vista frontale

Corner combination
Combinazione ad angolo

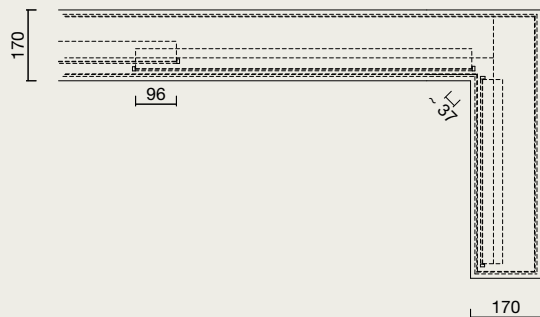

Upper view
Vista dall'alto

* Necessary space to install the system on wall (using wall cupboard fixing bar)
Spazio necessario per l'installazione a parete (con barra portapensile)

One on One / Horizontal

Front view
Vista frontale

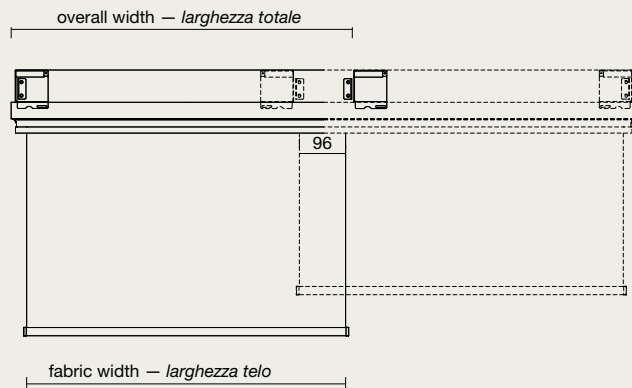

Version: **NOM**
Variante: *NOM*

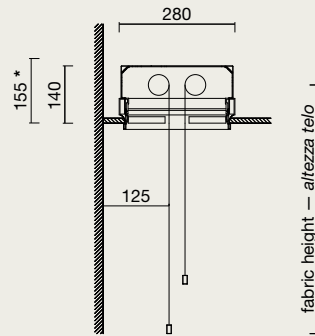

Fabric lowering: middle
Discesa telo: *centrale*

Multiple combination
Combinazione multipla

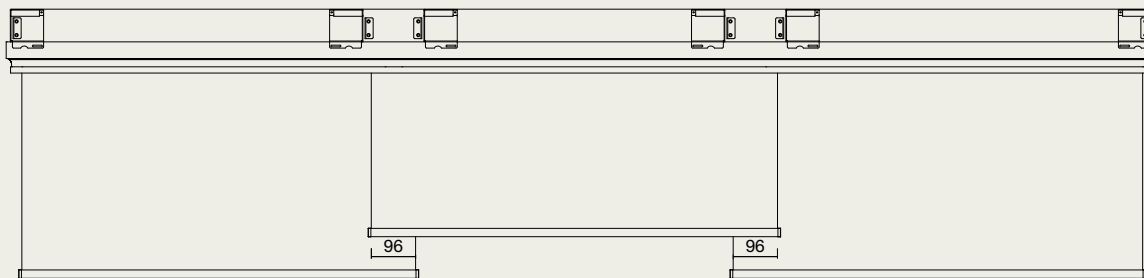

Front view
Vista frontale

* Necessary space to install the system on wall (using wall cupboard fixing bar)
Spazio necessario per l'installazione a parete (con barra portapensile)

Leeway

Top

Front view
Vista frontale

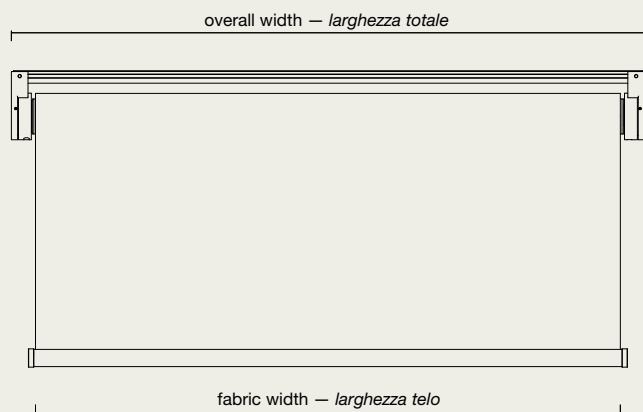

Side view
Vista laterale

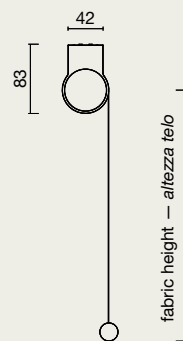

Fabric lowering: front (standard)
Discesa telo: avanti (standard)

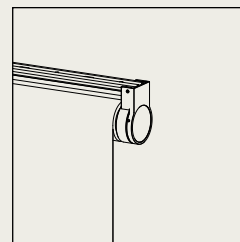

Fixed
Fisso

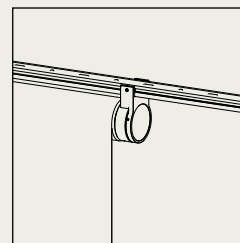

**Movable
along the track**
Spostabile
lungo il binario

Upper view
Vista dall'alto

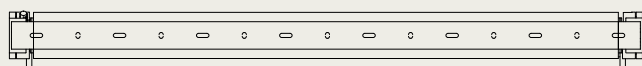

Multiple combination

Combinazione multipla

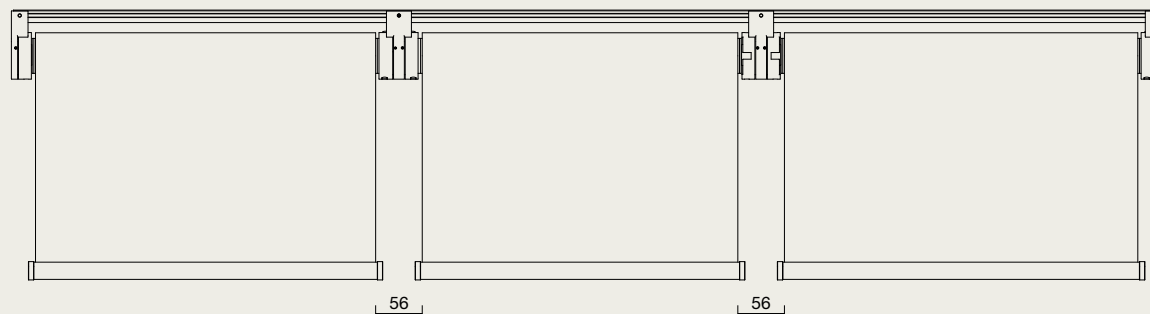

Front view
Vista frontale

Wall

Front view
Vista frontale

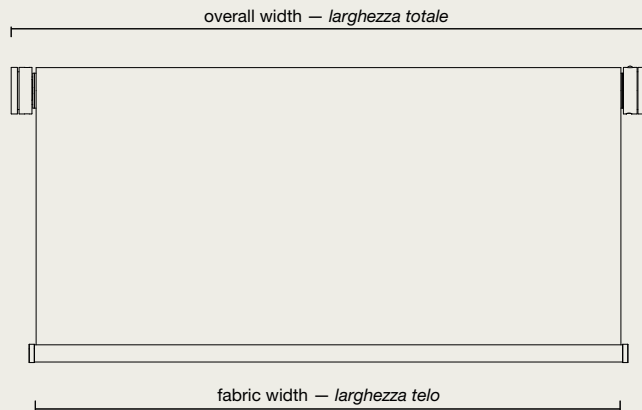

Upper view
Vista dall'alto

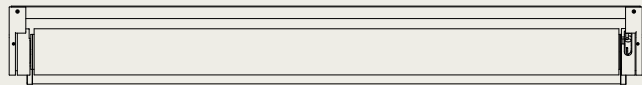

Side view
Vista laterale

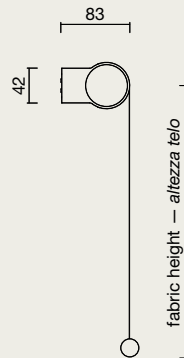

Fabric lowering: front (standard)
Discesa telo: avanti (standard)

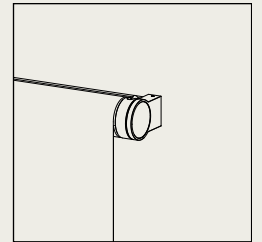

Fixed
Fisso

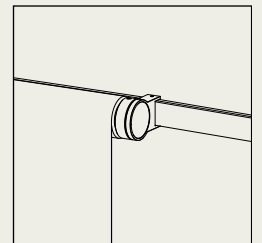

**Movable
along the track**
Spostabile
lungo il binario

Multiple combination

Combinazione multipla

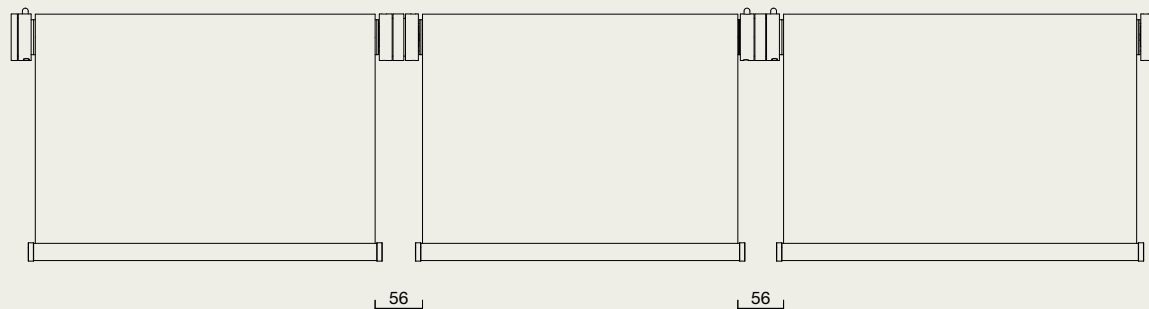

Front view
Vista frontale

Shard

Top

Front view
Vista frontale

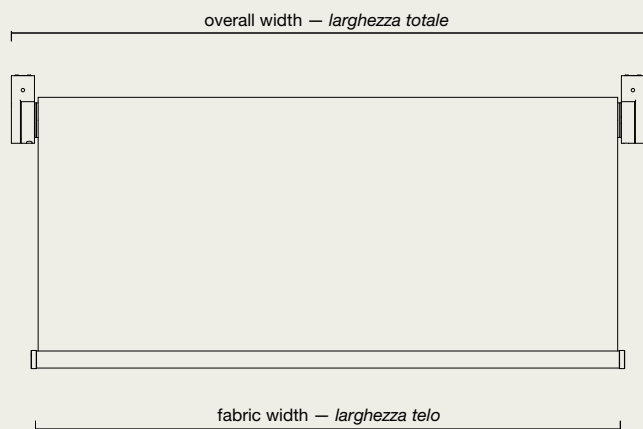

Side view
Vista laterale

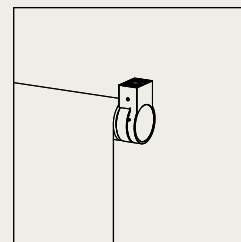
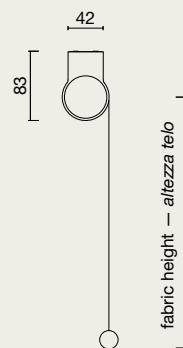

Fixed
Fisso

Fabric lowering: front (standard)
Discesa telo: avanti (standard)

Upper view
Vista dall'alto



Multiple combination

Combinazione multipla

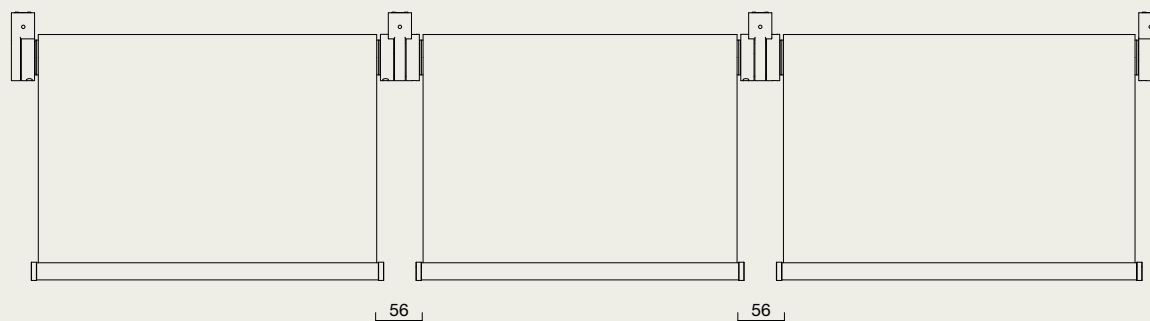

Front view
Vista frontale

Wall

Front view
Vista frontale

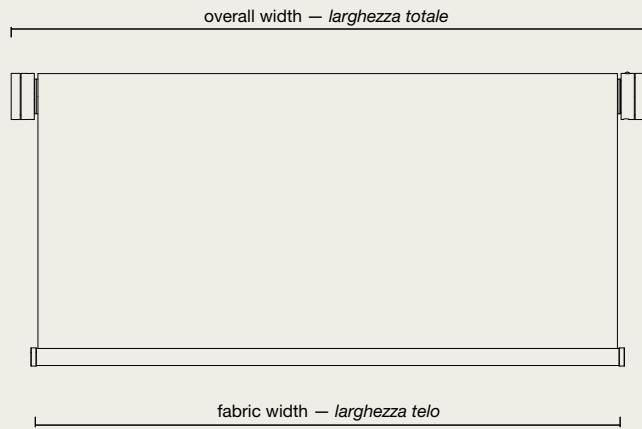

Side view
Vista laterale

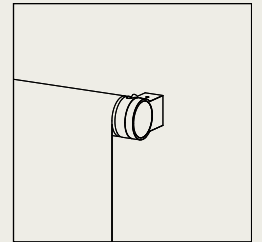
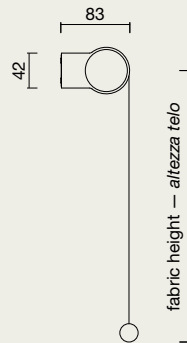

Fixed
Fisso

Fabric lowering: front (standard)
Discesa telo: avanti (standard)

Upper view
Vista dall'alto

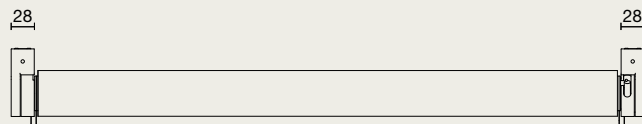

Multiple combination

Combinazione multipla



Front view
Vista frontale

Collection guide

Top

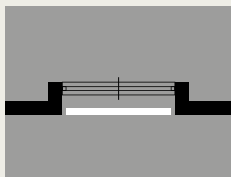

Minimum lateral extent
Minimo ingombro laterale

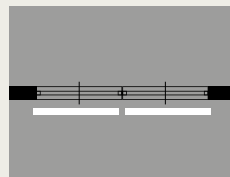

Minimum gap between fabrics
Minima distanza tra teli abbinati

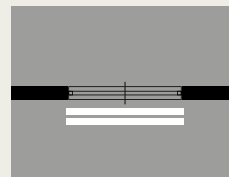

Double system (filtering/blackout)
Doppi (filtrante/oscurante)

Hyper / Standard	●	●	
Hyper / Maxi	●	●	
Hyper / Double Vertical	●	●	●
Hyper / Double Horizontal	●	●	●
Hyper / One on One Vertical	●	● (1)	
Hyper / One on One Horizontal	●	● (1)	
Leeway / Top	●	●	●
Shard / Top	●	●	●

Wall

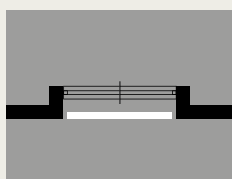

Minimum lateral extent
Minimo ingombro laterale

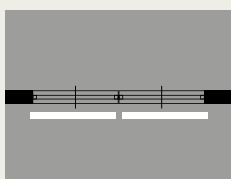

Minimum gap between cloths
Minima distanza tra teli abbinati

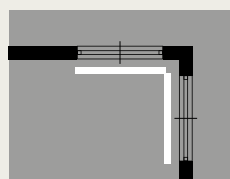

Corner fittings
Installazione ad angolo

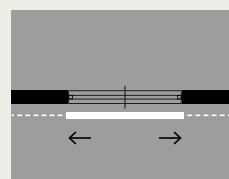

Lateral movement of supports on the track
Spostamento laterale del supporto sul sistema

Leeway / Wall	●	●	●	● (2)
Shard / Wall	●	●	●	

(1) Solution with overlapping fabrics
Soluzione con teli sovrapposti

(2) Requires the intervention of an installer
Richiede l'intervento di un installatore

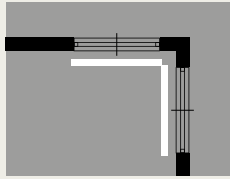

Corner fittings
Installazione ad angolo

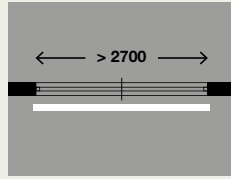

Width larger than 2700 mm
Larghezza superiore a 2700 mm



Recessed, floor-to-ceiling window
Ad incasso, vetrata a tutta altezza

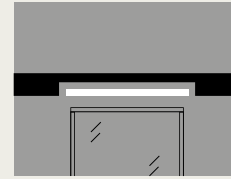

Reduced false ceiling
Controsoffitti di piccole dimensioni

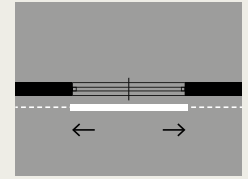

Lateral movement of supports on the track
Spostamento laterale del supporto sul sistema

•

•

•

•

•

•

•

•

•

•

•

•

•

• (2)

•

Download link

Scan the QR code on the right to download additional materials and technical information of Mycore products.

Scansiona il QR code sulla destra per scaricare materiali aggiuntivi e informazioni tecniche sui prodotti Mycore.



Finishes guide

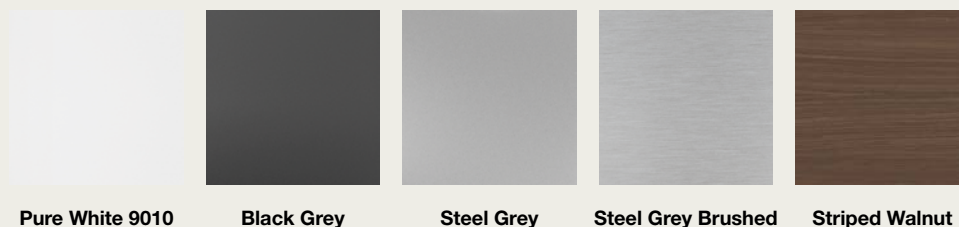

	Pure White 9010	Black Grey	Steel Grey	Steel Grey Brushed	Striped Walnut
Hyper / Standard	○	●		●	● (1)
Hyper / Maxi	○	●		●	● (1)
Hyper / Double Vertical	○	●		●	● (1)
Hyper / Double Horizontal	○	●		●	● (1)
Hyper / One on One Vertical	○	●		●	● (1)
Hyper / One on One Horizontal	○	●		●	● (1)
Leeway / Top	○	●	●		
Leeway / Wall	○	●	●		
Shard / Top	○	●	●		
Shard / Wall	○	●	●		

○ Finish proposed as default
Finitura proposta come opzione predefinita

(1) Real wood finish
Finitura in vero legno

**More information
on our website: mycore.it**

Mycore Designers Catalogue

Art direction,
concept, layout:
Arianna Balloch
Gruppo Pragma

Images:
Nudesign

Print:
Litostil

Mycore® is a registered trademark.
All designs are registered.
All information, drawings and
images are property of Mycore®
and can not be used without
prior written authorization.

*Mycore® è un marchio registrato.
Tutti i modelli sono registrati.
Tutti i dati, disegni ed immagini
sono di proprietà di Mycore®
e l'autorizzazione all'utilizzo deve
essere concessa in forma scritta.*

Printed on paper from well-managed forests
in accordance with natural resources.
*Stampato su carta proveniente da foreste
gestite nel rispetto delle risorse naturali.*



G.S. Srl
S.S. Pontebbana
Km 146,10 — n. 54/B
33017 Collalto — Tarcento
Udine — Italia
T. +39 0432 782052
mycore.it



mycore.it